

CONTENTS

Safety Precautions.....	1
Identification of Parts.....	2
Remote Controller.....	6
Operation Instructions.....	9
Maintenance	15
Protection.....	16
Troubleshooting.....	17
Installation Instructions.....	18
Trouble Display.....	29

Preparation Before Use

Before using the air conditioner, be sure to check and pre-set the following.

- **Remote Controller Pre-setting**

The remote controller is NOT preset as Cooling Only Air Conditioner or Heat Pump by manufacturer.

Each time after the remote Controller replaces of batteries or is energized, the arrowhead will flash on the Front of ?Heat? or ?Cool? on LCD of the remote controller.

User can preset the remote controller type depending on the air conditioner type you have purchased as follows :

Press any button when the arrowhead flashes and points at ?Heat?, then Heat Pump is set.

Press any button when the arrowhead flashes and points at ?Cool?, then Cooling Only is set.

If you don't press any button within 10 seconds, the remote controller is pre-set as Heat Pump automatically.

Note:

If the air conditioner you purchased is a Cooling Only one, but you pre-set the remote controller as Heat Pump, it doesn't bring any matter. But if the air conditioner you purchased is a Heat Pump one, and you preset the remote controller as Cooling Only, then you CAN NOT preset the Heating operation with the remote controller.

- **Auto-restart Pre-setting(optional):**

the appliance is preset as no Auto-restart function by manufacturer. If Auto-restart function is needed, follow the steps below to activate this function:

1) Make sure the air-con's power is off.

2) Press and hold the Emergency button (ON/OFF) on the indoor unit until then electrify.



















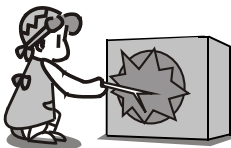

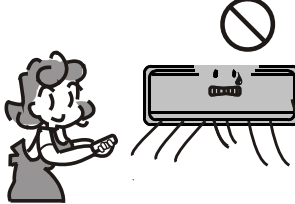

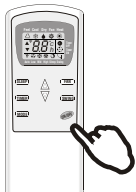

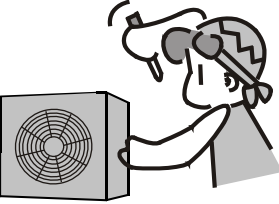
3) Keep pressing the Emergency button for more than 10 seconds until four short beeps are heard.

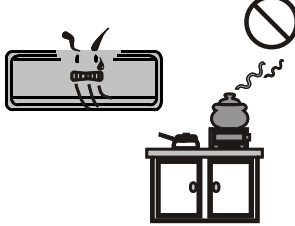
Then Auto-restart function is disabled. To activate the Auto-restart function, repeat above procedure until three short beeps are heard.

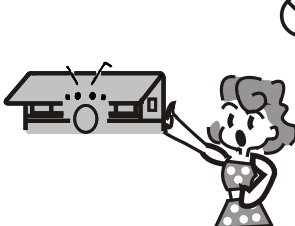
SAFETY PRECAUTIONS

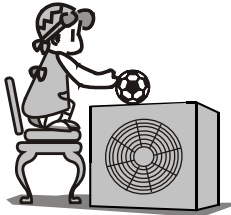
Symbols in this Owner's Manual are interpreted as shown below.

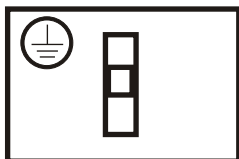
-  Be sure not to do.
-  The feature of the appliance, instead of a fault.
-  Pay attention to such a situation.
-  Be sure to follow this instruction.
-  Grounding is essential.
-  Warning: Incorrect handling could cause a serious hazard, such as death, serious injury, etc.

<p>Use correct power supply in accordance with the rating plate requirement. Otherwise, serious faults or hazard may occur or a fire maybe break out.</p> <p>If the supply cord is damaged, it must be replaced by the manufacturer, its service agent or similarly qualified persons in order to avoid a hazard.</p> 	  <p>Keep the power supply circuit breaker or plug from dirt. Connect the power supply cord to it firmly and correctly, lest an electric shock or a fire break out due to insufficient contact.</p>	   <p>Do not use the power supply circuit breaker or pull off the plug to turn it off during operation. This may cause a fire due to spark, etc.</p>
  <p>Do not knit, pull or press the power supply cord, lest the power supply cord be broken. An electric shock or fire is probably caused by a broken power supply cord.</p>	  <p>Never insert a stick or similar obstacle to the unit. Since the fan rotates at high speed, this may cause an injury.</p>	  <p>It is harmful to your health if the cool air reaches you for a long time. It is advisable to let the air flow be deflected to all the room.</p>
  <p>Turn off the appliance by remote control firstly before cutting off power supply if malfunction occurs.</p>	  <p>Do not repair the appliance by yourself. If this is done incorrectly, it may cause an electric shock, etc.</p>	  <p>Prevent the air flow from reaching the gas burners and stove.</p>
  <p>Do not touch the operation buttons when your hands are wet.</p>	  <p>Do not put any objects on the outdoor unit.</p>	   <p>It is the user's responsibility to make the appliance be grounded according to local codes or ordinances by a licenced technician.</p>

Notes: For the purpose of innovation and improvement, above products are subject to change without prior notice. The air conditioner is not a toy, please keep away from children. The appliance shall not be installed in the laundry!

IDENTIFICATION OF PARTS

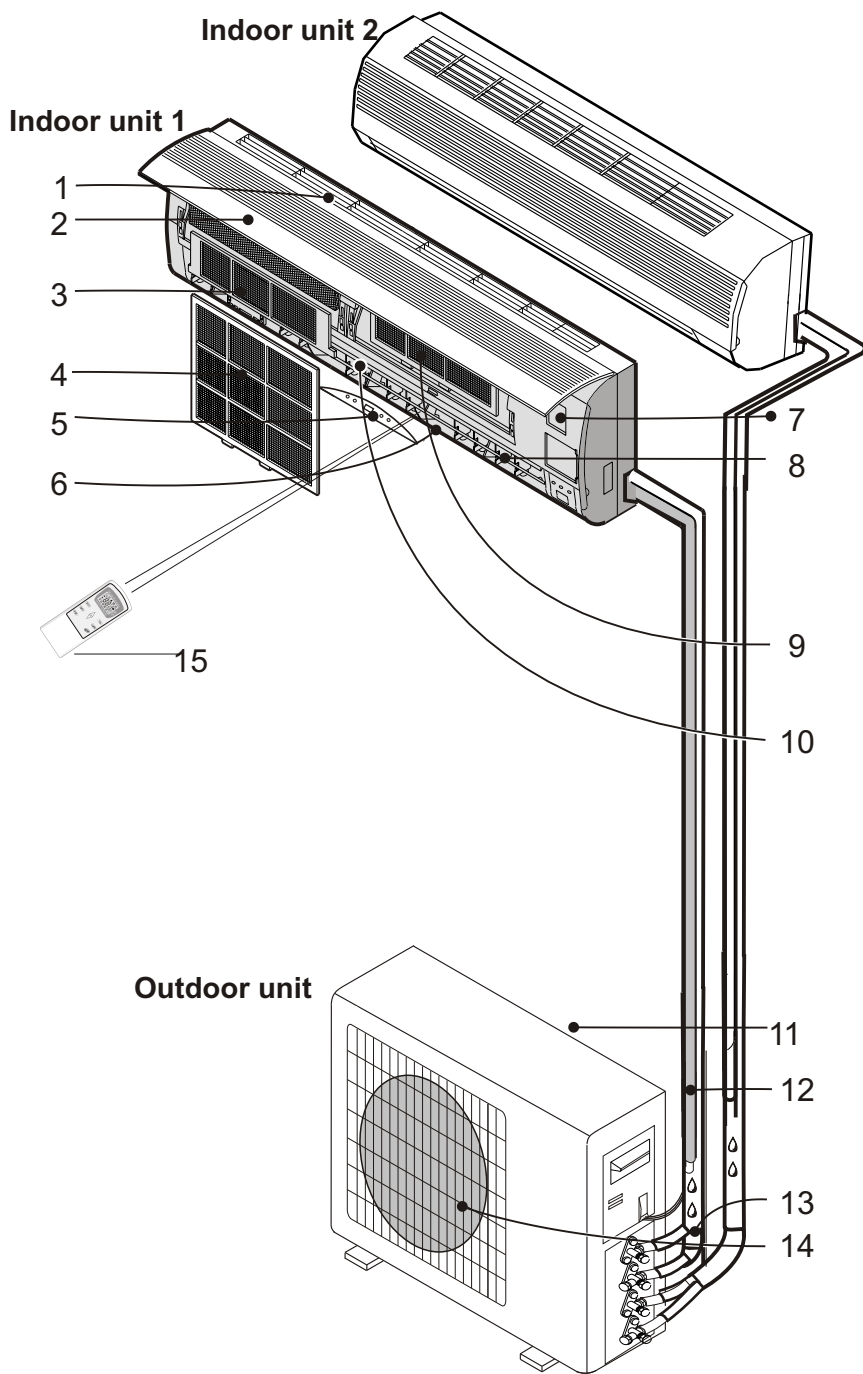

- 1. Air Intake
- 2. Front Panel
- 3. Electrostatic Filter (optional)
- 4. Air Filter
- 5. Display Panel
- 6. Air Outlet
- 7. Emergency Panel
- 8. Vertical Adjustment Louver
- 9. Charcoal Filter (optional)
- 10. Horizontal Adjustment Louver
- 11. Air Intake
- 12. Drain Hose
Note: Condensate water drains at COOLING or DRY operation.
- 13. Pipes and Power Connection Cord
- 14. Air Outlet
- 15. Remote Controller

☑ The figures in this manual are based on the external view of a standard model. Consequently, the shape may differ from that of the air conditioner you have selected.

IDENTIFICATION OF PARTS

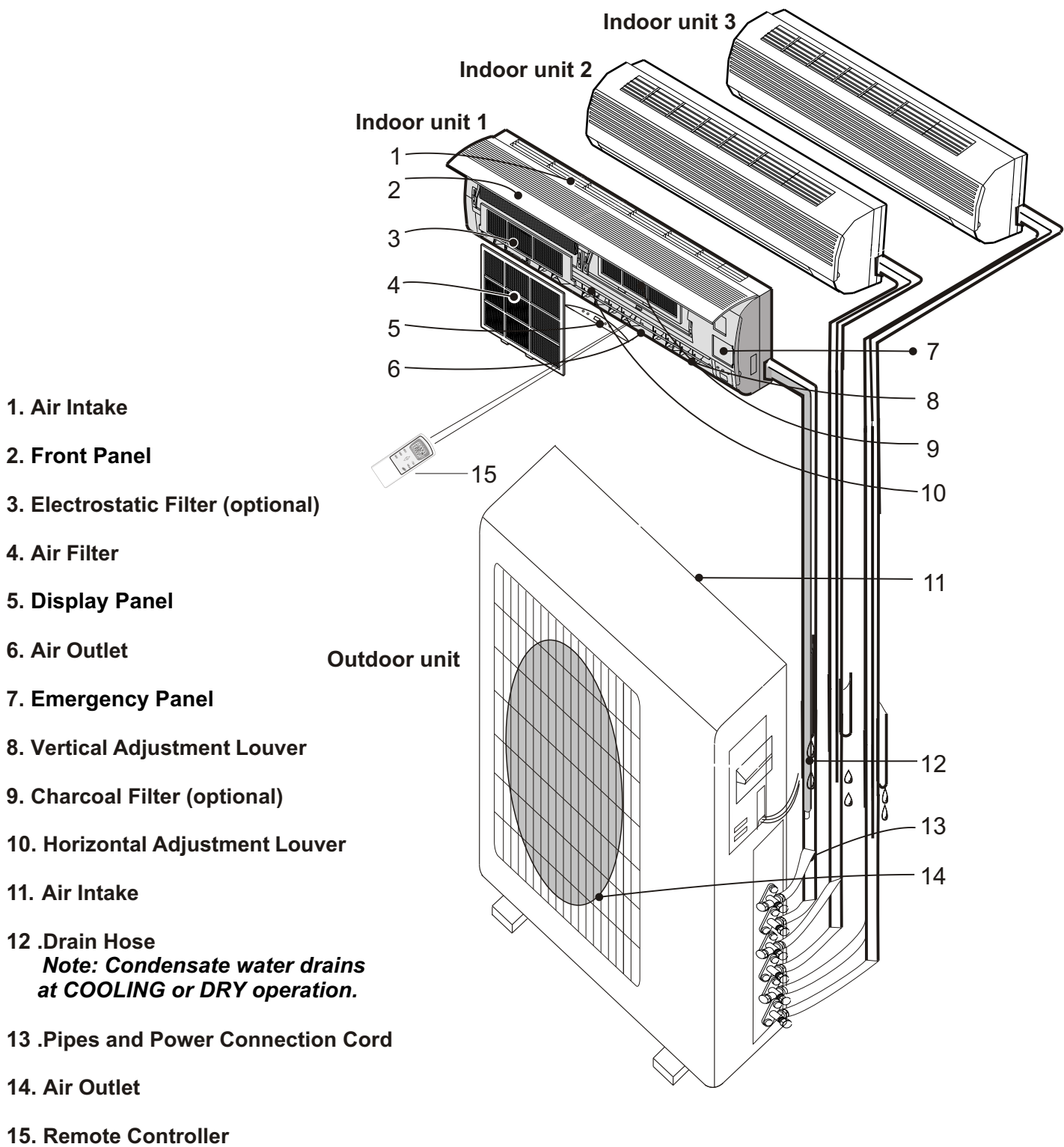

☑ The figures in this manual are based on the external view of a standard model. Consequently, the shape may differ from that of the air conditioner you have selected.

IDENTIFICATION OF PARTS

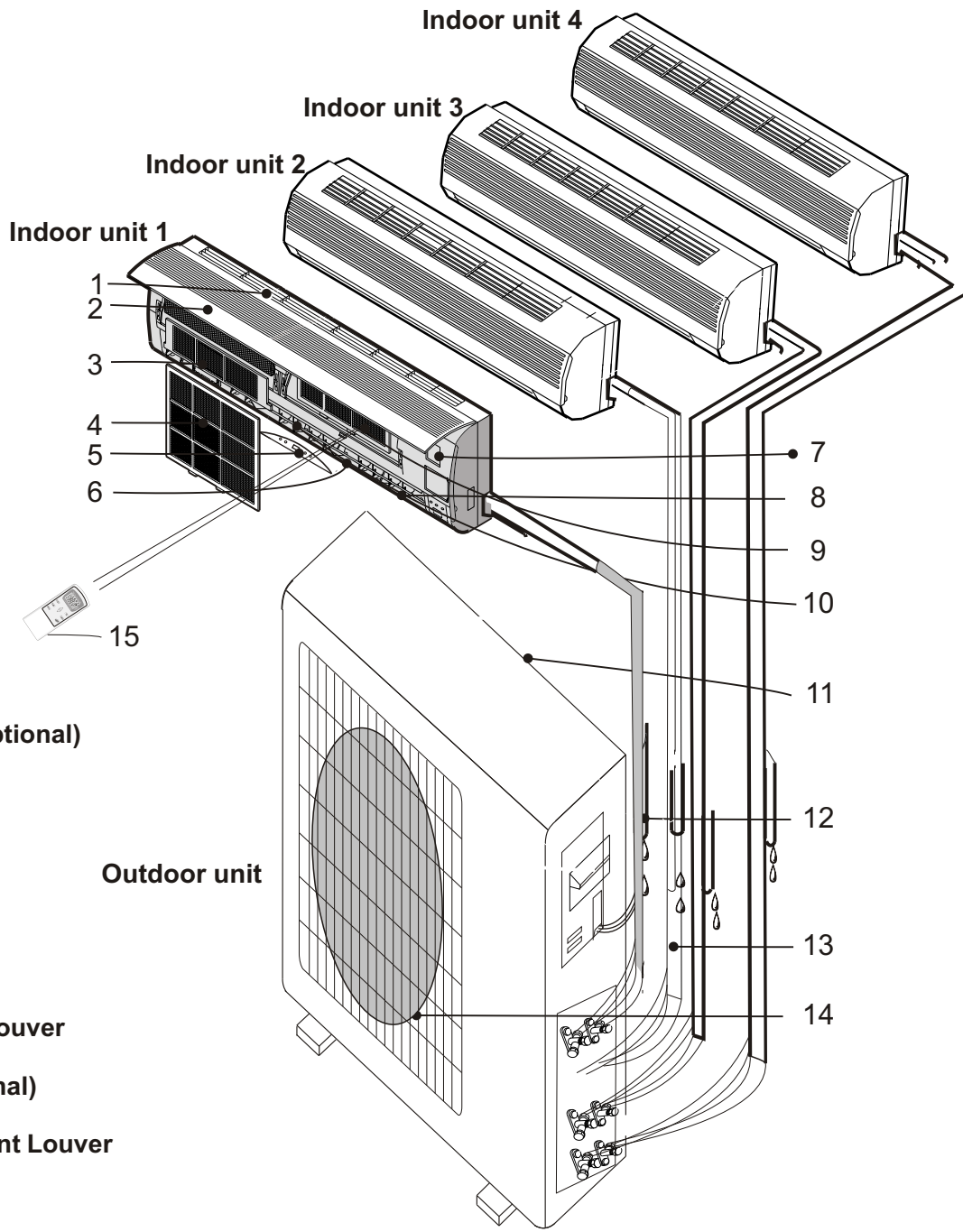

- 1. Air Intake
- 2. Front Panel
- 3. Electrostatic Filter (optional)
- 4. Air Filter
- 5. Display Panel
- 6. Air Outlet
- 7. Emergency Panel
- 8. Vertical Adjustment Louver
- 9. Charcoal Filter (optional)
- 10. Horizontal Adjustment Louver
- 11. Air Intake
- 12 .Drain Hose
Note: Condensate water drains at COOLING or DRY operation.
- 13 .Pipes and Power Connection Cord
- 14. Air Outlet
- 15. Remote Controller

☑ The figures in this manual are based on the external view of a standard model. Consequently, the shape may differ from that of the air conditioner you have selected.

IDENTIFICATION OF PARTS

Operating and Display

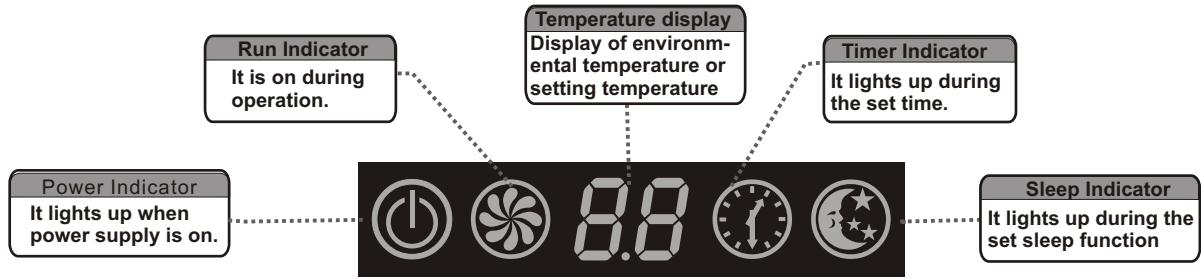

The above operating sketch map is suitable for Z ?BG series.

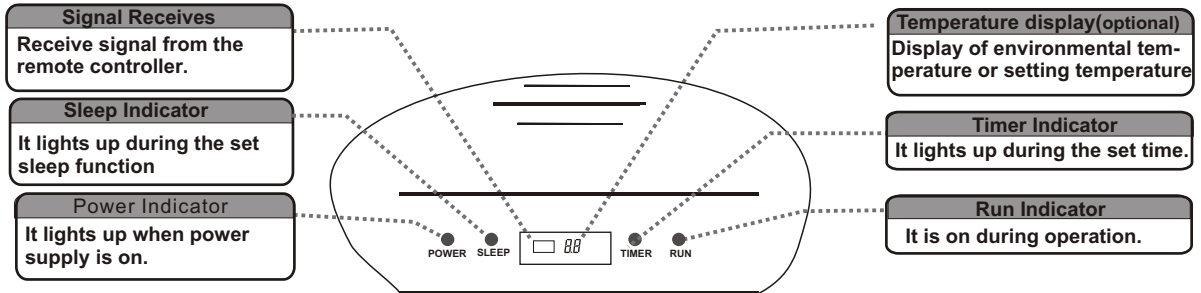

The above operating sketch map is suitable for C?D?E?F?G?H?J?K?M ?N?V?Z?BD?BE?BF?BH and BJ series.

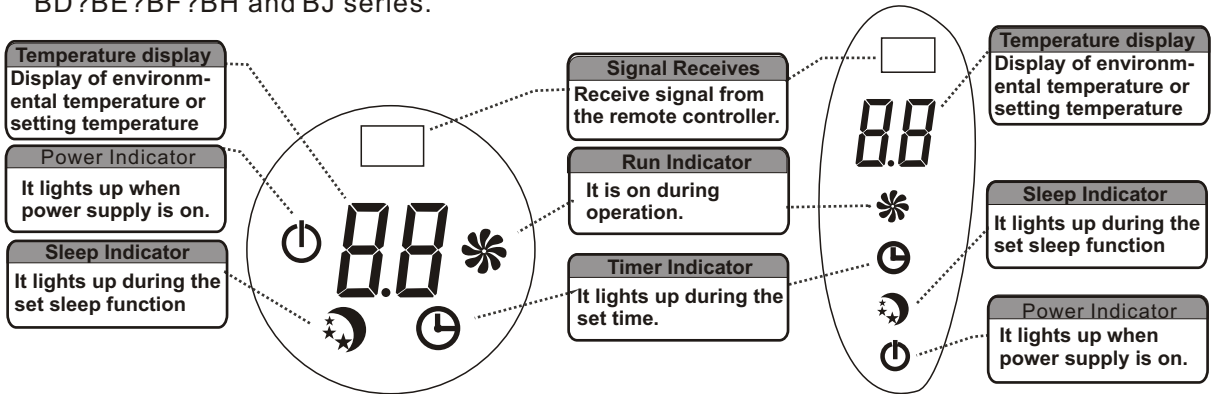

The above operating sketch map is suitable for L ?R and Y series.

The above operating sketch map is suitable for Q series.

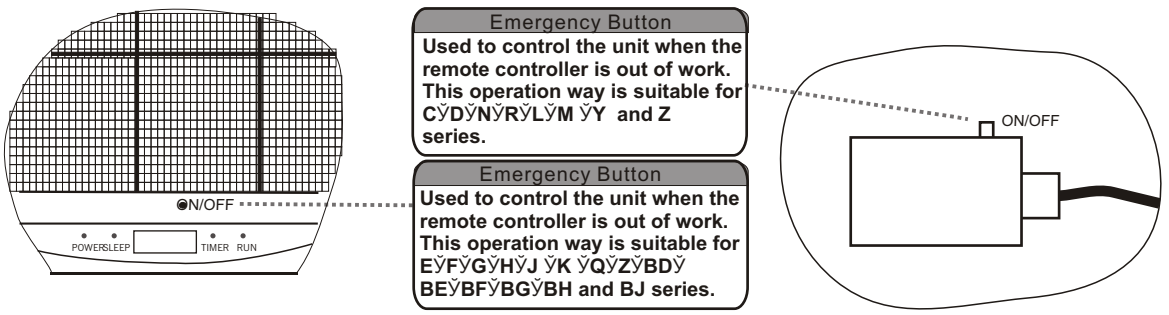

Remarks:When remote controller is out of work,open the panel and you can see emergency button there,see the above pictures.The emergency button for 15K?16K?18K?22K?24K ?28K and 30K series is at the top right,see ?ON/OFF?button there.

☑ The shape and position of the switches and indicators may vary from different models,but their function are simiar. If there is any difference between the sketch map and the substantiality,please subject to the substantiality.

REMOTE CONTROLLER

No.	Button	Function
1	▲ (TEMP UP)	Increase the temperature or time by 1 unit
2	▼ (TEMP DN)	Decrease the temperature or time by 1 unit
3	ON/OFF	To switch the conditioner on and off.
4	FAN	To select the fan speed of auto/low/mid/high
5	TIMER	To set automatic switching-on/off
6	SLEEP	To activate the function "SLEEP"
7	ECO	In cooling mode, press this button, the temperature will increase 2? on the base of setting temperature In heating mode, press this button, the temperature will decrease 2? on the base of setting temperature
8	MODE	To select the mode of operation
9	SUPER	In cooling mode, press this button, the unit will give the maximum cooling temperature with 16°C In heating mode, press this button, the unit will give the maximum heating temperature with 31°C
10	SWING	To activate or deactivate of the movement of the DEFLECTORS?.
11	CLOCK	When you press this button, the time will be flickering; then through "▲" and "▼", you can adjust the time (one time you press, one minute you adjust; and if you continue to press, the time change rapidly), after adjusting to your required time, please press this button again to fix the time.
12	DISPLAY	To switch on/off the LED display (if present)
13	HEALTHY	To switch - on /off HEALTHY function. It is a button which controls the ionizer or plasma generator only for inverter type.
14	3D	This button is useless for wall-mounted type. When you press "3D", the horizontal and vertical vanes will swing together at the same time.
15	RESET	To restart REMOTE CONTROL
16	ANTI-MILDEW	To activate the function ANTI-MILDEW

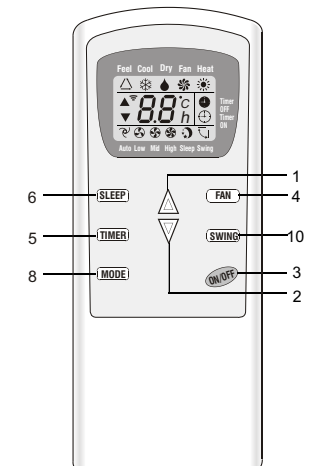
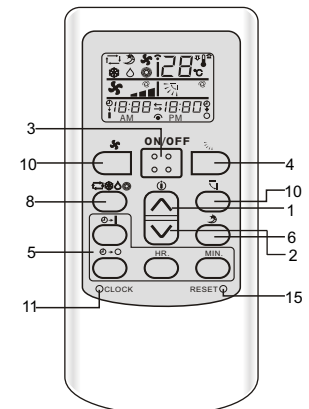
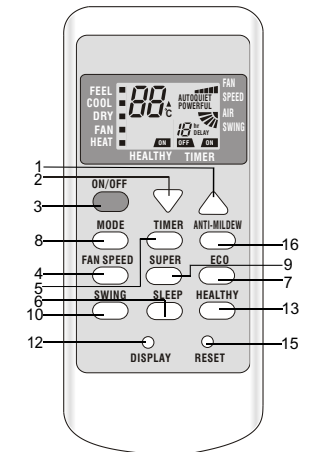
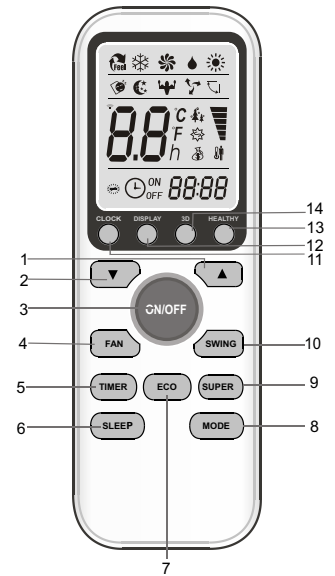

⚠ The outlook and some function of remote control may vary according to the model.

⚠ The shape and position of buttons and indicators may vary according to the model, but their function is the same.

6 ⚠ The unit confirms the correct reception of each press button with a beep.

REMOTE CONTROLLER

Remote control DISPLAY

Meaning of symbols on the liquid crystal display

No.	Symbols	Meaning
1		FEEL mode indicator
2		COOLING indicator
3		DEHUMIDIFYING indicator
4		FAN ONLY OPERATION indicator
5		HEATING indicator
6		SIGNAL RECEPTION indicator
7		TIMER OFF indicator
8		TIMER ON indicator
9		AUTO FAN indicator
10		LOW FAN SPEED indicator
11		MIDDLE FAN SPEED indicator
12		HIGH FAN SPEED indicator
13		SLEEP indicator
14		COMFORTABLE SLEEP indicator (optional)
15		I FEEL indicator(optional)
16		FLAP SWING indicator
17		FLAP and Deflectors SWING indicator
18		SUPER indicator
19		HEALTHY indicator
20		ECO indicator
21		ANTI-MILDEW indicator
22		BATTERY indicator
23		CLOCK indicator

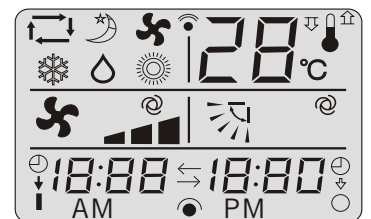
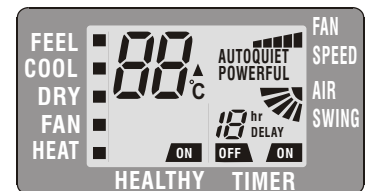

REMOTE CONTROLLER

How to Insert the Batteries

Remove the battery cover according to the arrow direction.

Insert new batteries making sure that the (+) and (-) of battery are matched correctly.

Re-attach the cover by sliding it back into position.

Note:
Use 2 LR03 AAA(1.5volt) batteries. Do not use rechargeable batteries.
Replace batteries with new ones of the same type when the display becomes dim.

Storage and Tips for Using the Remote Controller

The remote controller may be stored mounted on a wall with a holder.

Note: The remote controller holder is an optional part.

1 Please slide and remove the cover.

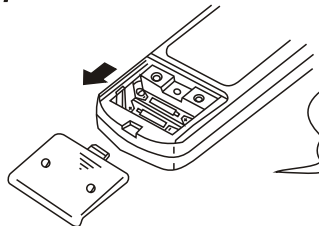

Slide the cover upwardly in the direction of the arrow.

2 Exchange the batteries.

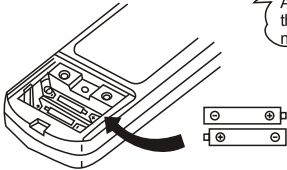

Attention to the ⊖ and ⊕ marks.

3 Install the cover.

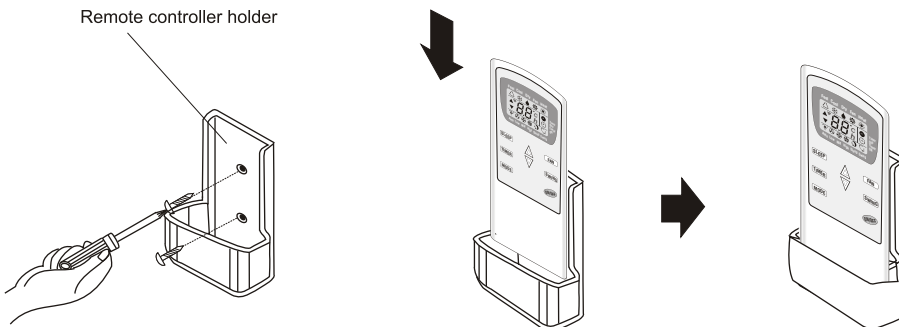

How to Use

To operate the room air conditioner, aim the remote controller to the signal receptor. The remote controller will operate the air conditioner at a distance of up to 7m when pointing at signal receptor of indoor unit.

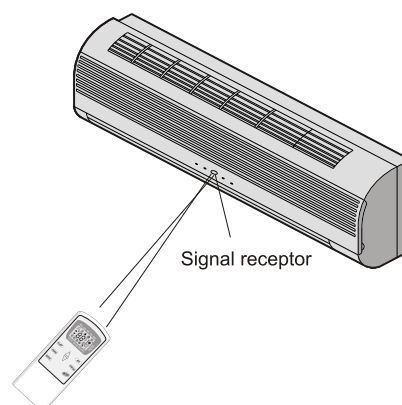

OPERATION INSTRUCTIONS

BATTERY INSTALLATION

When the signal receives very slowly or its display not so clearly, this time it may be the battery is not enough and replace them in time.

1. Please slide and remove the cover.
2. Exchange the battery
3. Install the cover.

Remote operation and attention item

1. There must be no obstacles within 8 metres when operating.
2. There is 30 degree error when the remote control aim at the signal window to operation.
3. The buzzer will sound when the remote control receive the signals
4. Do not let the remote control fall down or throw it away freely.
5. Do not the remote control expose to the sun directly
6. Do not let the remote control stays at a place with high temperature such as near electric carpet or a stove.
7. This remote control has the memory function, when press the ON/OFF button, it will display the operation estate last time.

When the unit receive the signal, at once it go into the last operation status.

The operation mode selection



Mode

- When the unit is at ON status, press the button  to change the operation mode. You can select the following running mode:

1. Running automatically (easy operation) Press the ON/OFF button on the remote controller at the first time or press MODE button into AUTO status. AC control the temperature into the most suitable temp. under this mode. The room temp. Determine the running content automatically. The content refer to the form below: (If the setting temperature is not satisfactory, you can adjust through temperature button), If you need to stop running, please press ON/OFF button.

ITEM Initial Temp.	Cooling Type		Heating Type	
	Mode	Initial Setting Temp.	Mode	Initial Setting Temp.
Above 26℃	Cooling	24℃	Cooling	24℃
25-26℃		Initial Room Temp. Subtracts 2?		Initial Room Temp. Subtracts 2?
23-25℃	Dehumidify	Initial Room Temp. Subtracts 2?	Dehumidify	Initial Room Temp. Subtracts 2?
Below 23℃			Heating	26℃

2. Cooling Operation

Set the temperature through ($\wedge \cdot \vee$) button under this mode. Press the () button to set the fan degree. Press the SWING button () can make the fan vane swing ceaselessly. Press the button () to adjust the air volume.

3. Dehumidification Operation

The fan speed of the indoor unit is controlled by microcomputer under this mode. The temperature adjustable button does not work. The microcomputer determines the temperature according to the room temp..

4. Fan Operation-Cooling Only

The outdoor unit does not work under this mode. Only the indoor fan works. At this time, AC is equal to the function of fan. It adjusts the fan degree, air volume and speed.

5. Heating Operation--Heating type

The operation way and cooling operation are the same under heating mode. Temperature, fan degree, air speed and volume, etc. are adjustable. Adjustable range of temp. is 16-31℃. Electric auxiliary of the electric auxiliary heater type exits and enters automatically according to the air outlet temperature when making heat.

OPERATION INSTRUCTIONS

FEEL mode operation procedure

Operates by selecting automatically the operation mode(HEAT, DRY, FAN, COOL) depending on the room temperature during starting.

With the remote controller pointing towards the air conditioner.

Turning on

Press  button, when the appliance receives the signal, the RUN indicator of the indoor unit lights up.



When the unit is not at FEEL mode.

Selecting FEEL mode





Press the MODE select button.
Move the MODE to the FEEL position.

Operation mode and temperature are determined by indoor temperature

Indoor temperature	Operation mode	Target temperature
Less than 20°C	HEATING (FOR HEAT PUMP TYPE) FAN (FOR COOL ONLY TYPE)	23°C
20°C~26°C	DRY	18°C
Over 26°C	COOLING	23°C

Air temperature adjustment is possible even during FEEL operation.
There are 6 levels of adjustment possible with the  button or the  button.

Setting temperature

Press the  button or the  button.
When the  button is pushed, the temperature will increase 1°C .
After temperature will increase 2°C , the indicator will not change.
When the  button is pushed, the temperature will reduce 1°C .
After temperature reduce 2°C , the indicator will not change.

NOTE

There will be a delay when changing mode is made during the operation.
As there might not be air blown out.

The operation of the AUTO mode can be performed by only pressing the ON/OFF button from the next time.



- If you don't like the content of FEEL mode operation, change to HEATING, DRY or COOLING than FEEL.

OPERATION INSTRUCTIONS

TIMER mode



1. Timer Setting:

- ① When the air conditioner starts, check and set the present time, if not, timer does not work.
- ② For TIMER ON function key For TIMER OFF function key
- ③ Press () Button to set the time
 Time setting regards 10 minutes as unit. Only when or appear on the display screen, time setting can work. The sign flash for one minutes then disappears (press & button, time unit changes basic on unit of 1 hour and 10 minutes.).

Note: when performing the TIMER function, please ensure put the remote controller in a right place where the signal can be received by indoor unit. After power off or curcuit breaks, you need to reset the TIMER, otherwise there will be mistaken action and error .

2. Cancel TIMER function

Cancel TIMER ON function, please press button again.
 Cancel TIMER OFF function, please press button again.
 After TIMER is cancel, the time setting disappears on the display screen of remote controller.

3. TIMER procedure operate

and can perform together. Operation will act first according to the present time. (shows TIMER ON and TIMER OFF order sequences.)

For example: set the Auto On time is 8 a.m., The Auto Off time is 8 p.m., Or when at the different time, the order sequence displays on the remote controller will be different.

Present time is 10 a.m.and shown

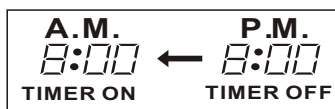

Present time is 10 p.m.and shown

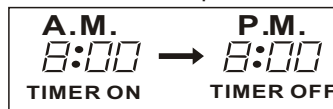

4. Other functions

Set the present time:
 Present time is set at 12 a.m. automatically after installing battery.

- a. Press the CLOCK switch on the remote controller, A.M. And P.M. will flashing, then you can set the present time.
- b. Press Hr. Button.
- c. Press Min. Button.
- d. Press CLOCK switch, the flashing status of timing indication become stable. Time setting finish.

Note : Timer setting is basic on the present time.
 Please set the present time properly.

OPERATION INSTRUCTIONS

TIMER mode

It is convenient to set the timer on with the **TIMER** button when you go out in the morning to achieve a comfortable room temperature when you get home. You can also set timer off at night to enjoy a good sleep.



Timer-setting

When the remote controller is off, press the **TIMER** button to set a switch-on timer, press again, the setting will be cancel.



When the remote controller is on, press the **TIMER** button to set a switch-off timer, press again, the setting will be cancel.

Press **UP** and **DOWN** button to set time.
Time setting is 30-minutes.

Note: After setting the timer, check that **TIMER INDICATOR** lamp of the indoor unit lights.

MODE CONFLICT

When two indoor unit start, one indoor unit operates at a defined mode (such as **COOL**), another one operates at a conflicted mode (such as **HEAT**), the heating indoor unit takes priority of running normally and the cooling one stops or remains waiting for control signal (not an obstacle).

OPERATION INSTRUCTIONS

MODE CONFLICT

While operating both indoor units simultaneously??Primary unit first? is effective?it means that the first operating unit is the primary unit, if the secondary unit operate different mode with the primary unit, then the secondary units will appear ?Mode conflict?(all the lights and display will flash 5 times, then it will stop working).

Unit A \ Unit B	Cool	Heat	Dehumidify	Fan	Auto
Cool	Enable	Disable	Enable	Enable	Only run on the same mode as the primary unit
Heat	Disable	Enable	Disable	Enable	
Dehumidify	Enable	Disable	Enable	Enable	
Fan	Enable	Enable	Enable	Enable	
Mandatory cool	Run on the same mode as the primary unit				
Auto cool	Enable	Disable	Enable	Enable	
Auto heat	Disable	Enable	Disable	Enable	
Auto fan	Enable	Enable	Enable	Enable	

OPERATION INSTRUCTIONS

MODE CONFLICT

While triple indoor units are simultaneously operated, the other two or three units cannot be operated in a mode conflicting to that of the primary unit. The unit initially started should be considered as the primary unit. In the circumstance that the operable modes are conflicting with each other, the TIMER lamp located on the display panel of the second. This can be rectified through changing the operable mode of the conflicting unit.

Unit A \ Unit B/C/D	Cool	Heat	Dehumidify	Fan	Auto
Cool	Enable	Disable	Enable	Enable	Only run on the same mode as the primary unit
Heat	Disable	Enable	Disable	Enable	
Dehumidify	Enable	Disable	Enable	Enable	
Fan	Enable	Enable	Enable	Enable	
Mandatory cool	Run on the same mode as the primary unit				
Auto cool	Enable	Disable	Enable	Enable	
Auto heat	Disable	Enable	Disable	Enable	
Auto fan	Enable	Enable	Enable	Enable	

MAINTENANCE

Front panel maintenance

1 Cut off the power supply

Turn off the appliance first before disconnecting from power supply.

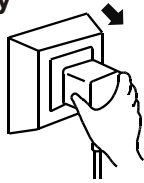

2

Grasp position "a" and pull outward to remove the front panel.

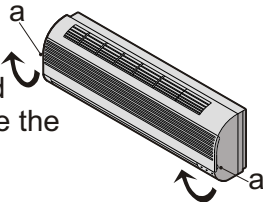

3 Wipe with a soft and dry cloth.

Use lukewarm water (below 40°C) to clean if the appliance is very dirty.



Use a dry and soft cloth to clean it.

4 Never use volatile substance such as gasoline or polishing powder to clean the appliance.



5 Never sprinkle water onto the indoor unit

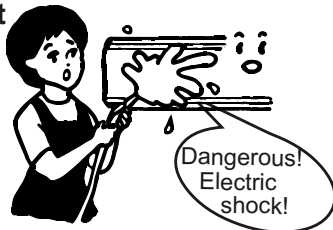

6 Reinstall and shut the front panel.

Reinstall and shut the front panel by pressing position "b" downward.

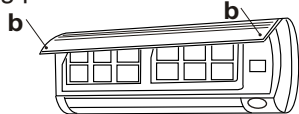

Air filter maintenance

It is necessary to clean the air filter after using it for about 100 hours.

Clean it as follows:

1 Stop the appliance, disconnect from power supply and remove the air filter.

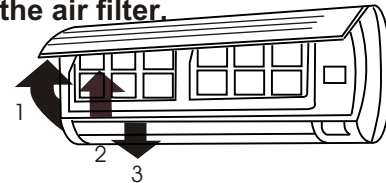

1. Open the front panel.
2. Press the handle of the filter gently from the front.
3. Grasp the handle and slide out the filter.

2 Clean and reinstall the air filter.

If the dirt is conspicuous, wash it with a solution of detergent in lukewarm water. After cleaning, dry well in shade.



3 Close the front panel again.

- ☑ *Clean the air filter every two weeks if the air conditioner operates in an extremely dusty environment.*

*Means for disconnection from the supply having a contact separation of at least 3 mm in all poles must be incorporated in the fixed wiring according to the wiring rules.

PROTECTION

Operating condition

The protective device maybe trip and stop the appliance in the cases listed below.

HEATING	Outdoor air temperature is over 24°C
	Outdoor air temperature is below -15°C
	Room temperature is over 27°C
COOLING	Outdoor air temperature is over *48°C
	Room temperature is below 21°C
DRY	Room temperature is below 18°C

* For Tropical (T3) Climate condition models, the temperature point is 52°C instead of 48°C

If the air conditioner runs in COOLING or DRY mode with door or window opened for a long time when relative humidity is above 80%, dew may drip down from the outlet.

Noise pollution

- Install the air conditioner at a place that can bear its weight in order to operate more quietly.
- Install the outdoor unit at a place where the air discharged and the operation noise would not annoy your neighbors.
- Do not place any obstacles in front of the air outlet of the outdoor unit lest it increases the noise level.

Features of protector

- 1 The protective device will work at following cases.**
 - Restarting the unit at once after operation stops or changing mode during operation, you need to wait 3 minutes.
 - Connect to power supply and turn on the unit at once, it may start 20 seconds later.
- 2**
 - If all operation has stopped, press **ON/OFF** button again to restart.
 - Timer should be set again if it has been canceled.

Inspection

After using for long time, the air conditioner should be inspected on the following items.

- Overheat of the power supply cord and plug or even a burned smell.
 - Abnormal operating sound or vibration.
 - Water leakage from indoor unit.
 - Metal cabinet electrified.
- ❑ **Stop the air conditioner if above trouble occurs. It is advisable to have a detail inspection after using it for 5 years even if none above occurs.**

Features of HEATING mode

Preheat

At the beginning of **HEATING** operation, the airflow from indoor unit is discharged 2-5 minutes later.

Afterheat

After the finishing of **HEATING** operation, the airflow from indoor unit is discharged 2-5 minutes.

Defrost

In **HEATING** operation the appliance will defrost (de-ice) automatically to raise efficiency. This procedure usually lasts 2-10 minutes. During defrosting, fans stop operation. After defrosting completes, it returns to **HEATING** mode automatically.

Note: Heating is NOT available for cooling only air conditioner models.

TROUBLE SHOOTING

The following cases may not always be a malfunction, please check it before asking for service.

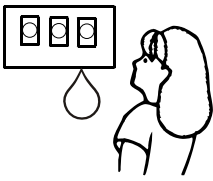
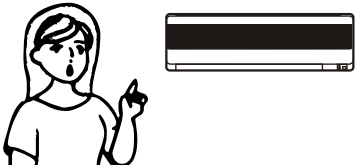
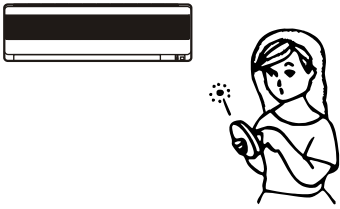
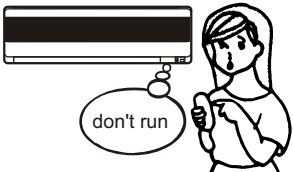
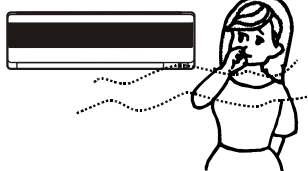
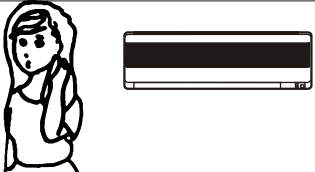
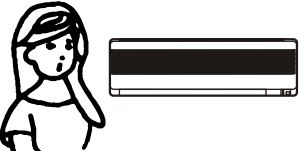
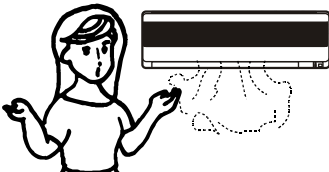
Trouble	Analysis
<p>Does not run</p> 	<ul style="list-style-type: none"> • If the plug is not properly plugged. • If batteries in the remote controller exhausted. • If the protective device works to protect the appliance. • If the protector trip or fuse is blown.
<p>No cooling or heating air</p> 	<ul style="list-style-type: none"> • Are the intakes and outlets of the air conditioner blocked? • Is the temperature set properly? • Is the air filter dirty?
<p>Ineffective control</p> 	<ul style="list-style-type: none"> • If strong interference (from excessive static electricity discharge, power supply voltage abnormality) presents, operation will be abnormal. At this time, disconnect from the power supply and connect back 2-3 seconds later.
<p>Does not operate immediately</p> 	<ul style="list-style-type: none"> • Changing mode during operation, 3 minutes will delay.
<p>Peculiar odor</p> 	<ul style="list-style-type: none"> • This odor may come from another source such as furniture, cigarette etc, which is sucked in the unit and blows out with the air.
<p>A sound of flowing water</p> 	<ul style="list-style-type: none"> • Caused by the flow of refrigerant in the air conditioner, not a trouble. • Defrosting sound in heating mode.
<p>Cracking sound is heard</p> 	<ul style="list-style-type: none"> • The sound may be generated by the expansion or contraction of the front panel due to change of temperature.
<p>Spray mist from the outlet</p> 	<ul style="list-style-type: none"> • Mist appears when the room air becomes very cold because of cool air discharged from indoor unit during COOLING or DRY operation mode.
<p>The compressor indicator (red) lights on constantly, and indoor fan stops.</p>	<ul style="list-style-type: none"> • The unit is shifting from heating mode to defrost. The indicator will lights off within ten minutes and returns to heating mode.

INSTALLATION INSTRUCTIONS

Installation diagram

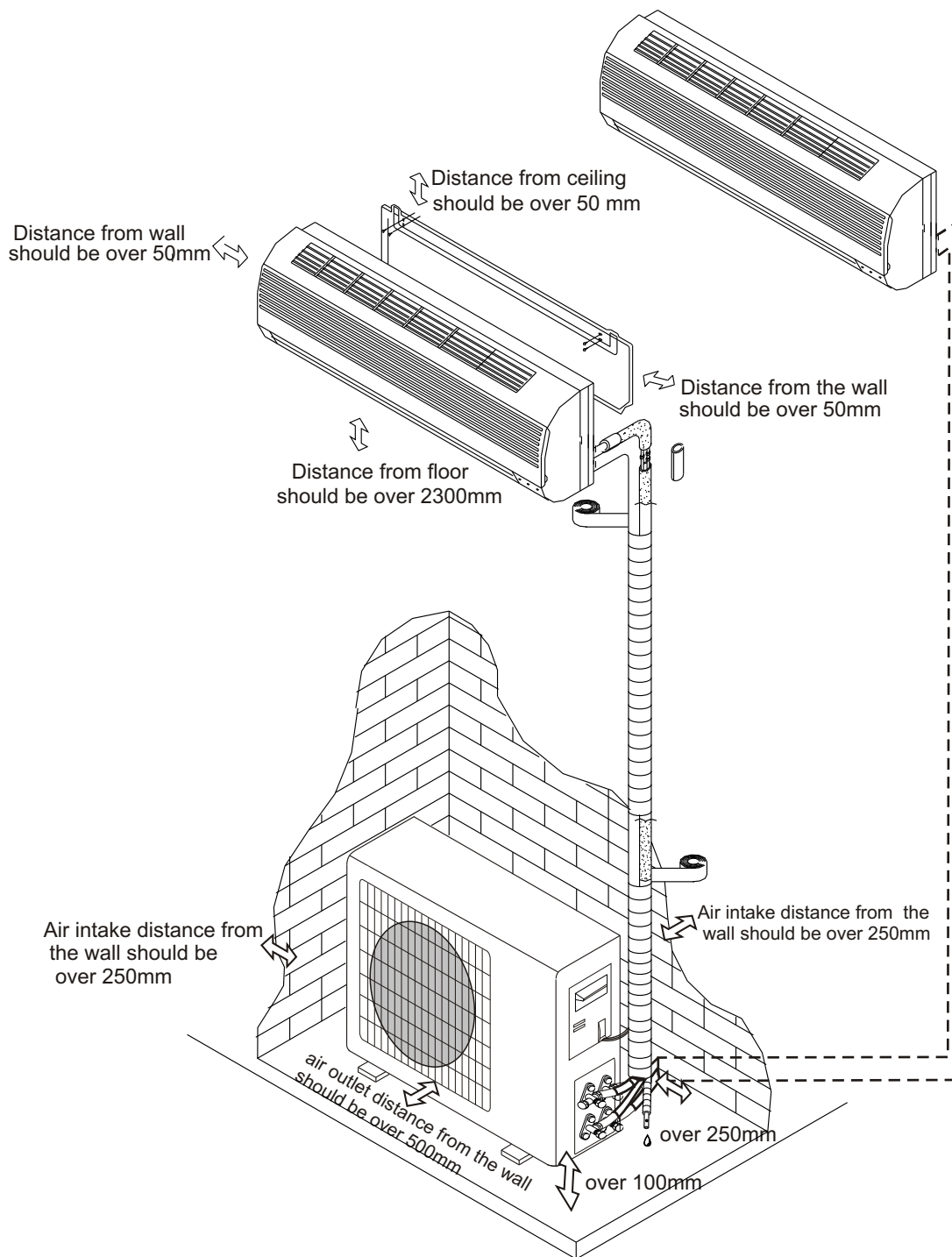

NOTE

- Above figure is only a simple presentation of the unit, it may not match the external appearance of the unit you purchased.
- Installation must be performed in accordance with the national wiring standards by authorized personnel only.
- Outdoor unit must be install where the distance between the base of outdoor unit and ground over 100mm to install drain hose and to avoid damaging drain elbow.

INSTALLATION INSTRUCTIONS

Installation diagram

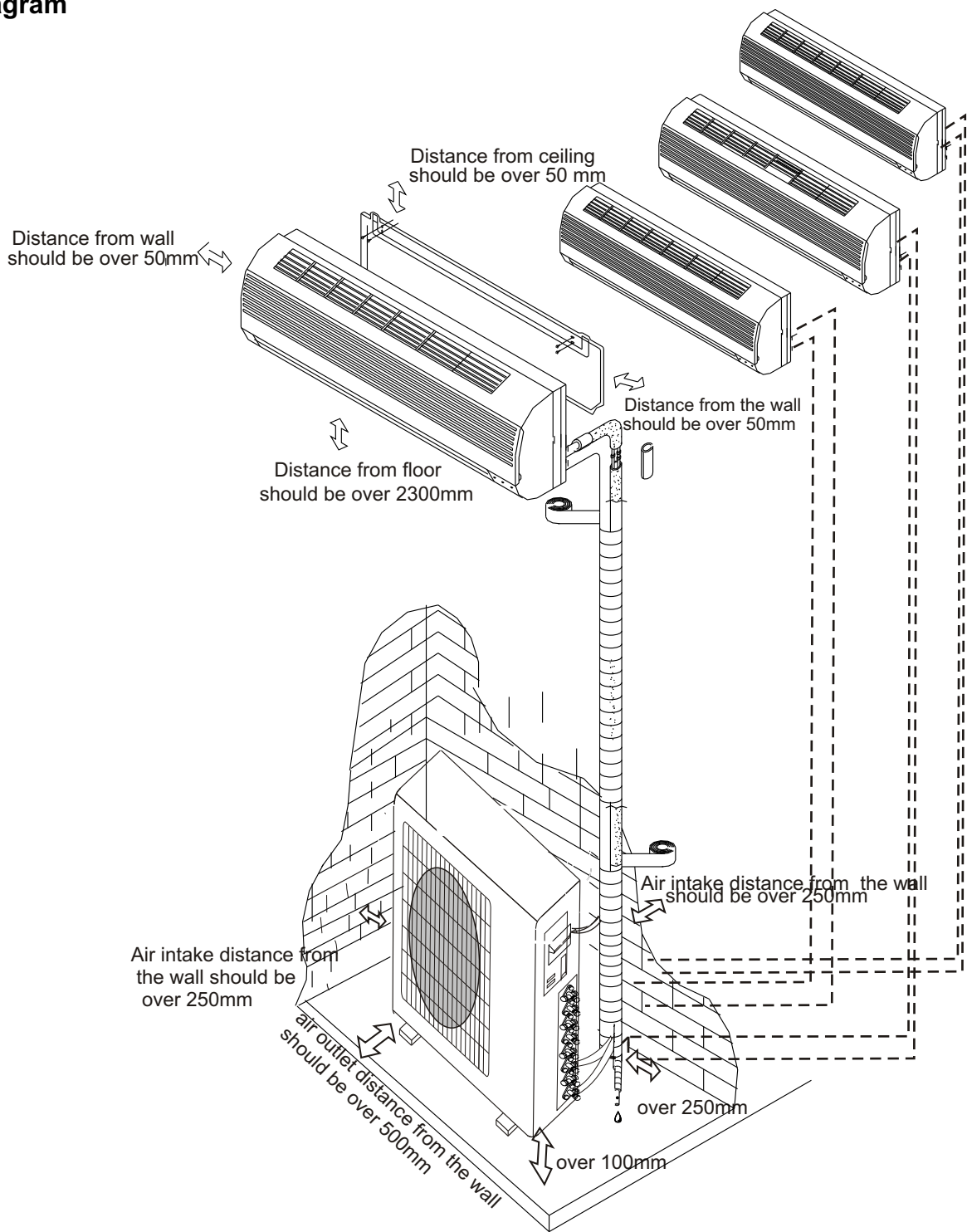

NOTE

- Above figure is only a simple presentation of the unit, it may not match the external appearance of the unit you purchased.
- Installation must be performed in accordance with the national wiring standards by authorized personnel only.
- Outdoor unit must be install where the distance between the base of outdoor unit and ground over 100mm to install drain hose and to avoid damaging drain elbow.

INSTALLATION INSTRUCTIONS

Connecting of the Cable

Wiring between the indoor and outdoor units:

- 1) Remove the PCB cover from the indoor unit;
- 2) Refer to the wiring diagram attached to indoor unit when connecting cords to indoor unit terminals;
- 3) Reinstall the PCB cover. Be sure that the side B are at outside.

Select the best location

Location for Installing Indoor Unit

- Where there is no obstacle near the air outlet and air can be easily blown to every corner.
- Where piping and wall hole can be easily arranged.
- Keep the required space from the unit to the ceiling and wall according to the wiring diagram.
- Where the air filter can be easily removed.
- Keep the unit and remote controller 1m or more apart from television, radio etc.
- To prevent the effects of a fluorescent lamps, keep as far as possible.
- Do not put anything near the air inlet to obstruct it from air absorption.
- Where there is strong enough to bear the weight and is not tend to increase operation noise and vibration.

⚠ The appliance shall not be installed in the laundry.

The appliance shall be installed in a minxium distance 500 mm from flammable materials.

Location for Installing Outdoor Unit

- Where it is convenient to install and well ventilated; avoid installing it where flammable gas could leak.
- Keep the required distance apart from the wall.
- Keep the outdoor unit away from a place of greasy dirt, vulcanization gas exit or high salty seashore.
- Avoid installing it at the roadside where there is a risk of muddy water.
- A fixed base where is not subject to increasing operation noise.
- Where there is not any blockage for air outlet.

☑ The refrigerant charge volume for the unit is based on using a 5m connecting pipe. If the connecting pipe's length is longer than 5m, it is advisable to charge additional refrigerant for the unit in order to achieve better operation.

Specification of Liquid pipe	Max. length	Additional refrigerant
φ6.35	15m	(L-5)X0.015 kg

(* "L" refers to length of connection pipe.)

The additional refrigerant should be charged from the service port of the 3-way valve when the appliance is operating in cooling mode.

Do not allow air enter the refrigeration system while charging refrigerant.

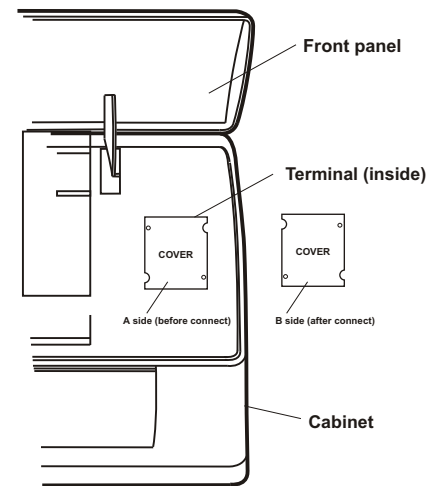

Installation Diagram

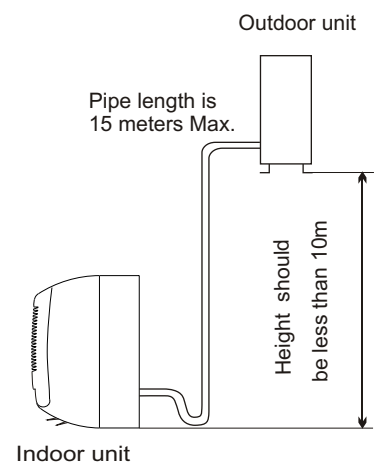
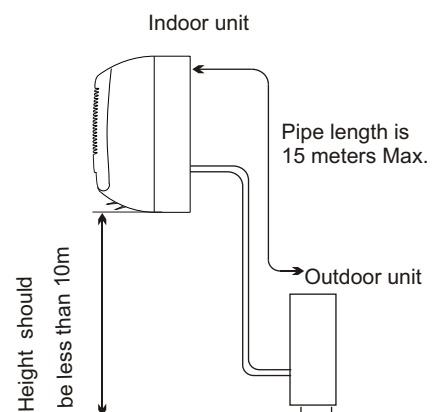

INSTALLATION INSTRUCTIONS

Indoor unit installation

1. Installing the Mounting Plate

- Decide an installing location for the mounting plate according to the indoor unit location and piping direction.
- Keep the mounting plate horizontally with a horizontal ruler or dropping line.
- Drill holes of 32mm in depth on the wall for fixing the plate.
- Insert the plastic plugs to the hole, fix the mounting plate with tapping screws.
- Inspect if the mounting plate is well fixed. Then drill a hole for piping.

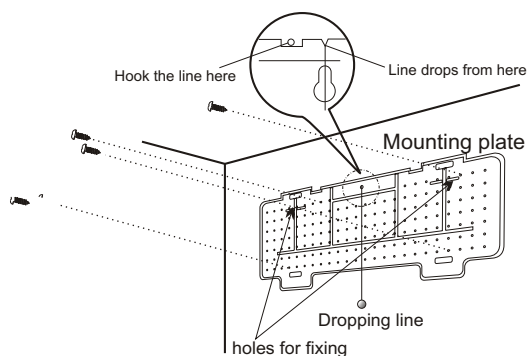

Note: The shape of your mounting plate may be different from the one above, but installation method is similar.

2. Drill a Hole for Piping

- Decide the position of hole for piping according to the location of mounting plate.
- Drill a hole on the wall. The hole should tilt a little downward toward outside.
- Install a sleeve through the wall hole to keep the wall tidy and clean.

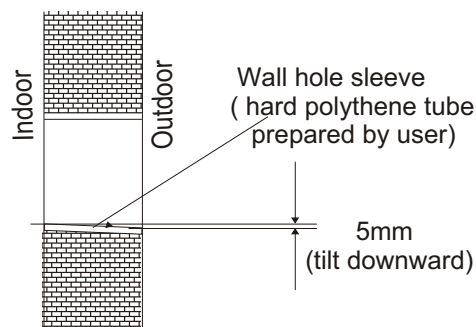

3. Indoor Unit Piping Installation

- Put the piping (liquid and gas pipe) and cables through the wall hole from outside or put them through from inside after indoor piping and cables connection complete so as to connect to outdoor unit.
- Decide whether saw the unloading piece off in accordance with the piping direction. (as shown below)

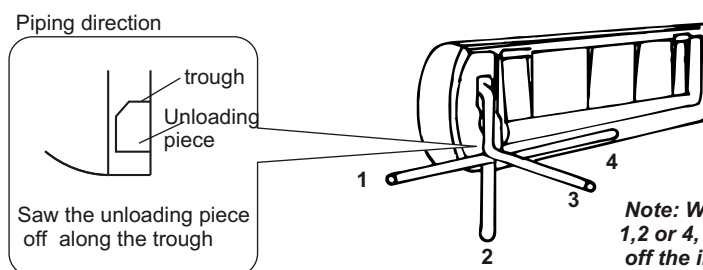

- After connecting piping as required, install the drain hose. Then connect the power cords. After connecting, wrap the piping, cords and drain hose together with thermal insulation materials.

INSTALLATION INSTRUCTIONS

NOTE

• **Piping Joints Thermal Insulation:**
Wrap the piping joints with thermal insulation materials and then wrap with a vinyl tape.

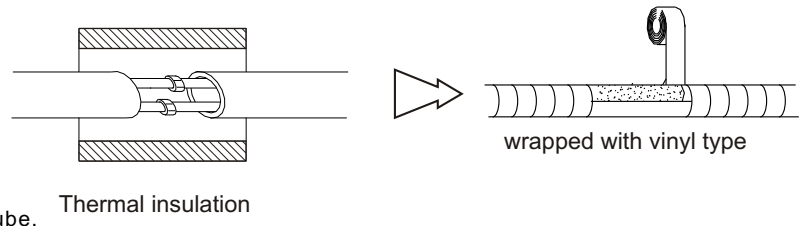

• The temperature of refrigerant circuit will be high, please keep the interconnection cable away from the copper tube.

• **Piping Thermal Insulation:**

- a. Place the drain hose under the piping.
 - b. Insulation material uses polythene foam over 6mm in thickness.
- Note: Drain hose is prepared by user.*

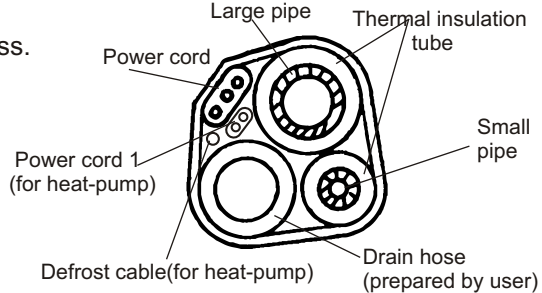

• Drain pipe should point downward for easy drain flow. Do not arrange the drain pipe twisted, sticking out or wave around, do not immerse the end of it in water.

If an extension drain hose is connected to the drain pipe, make sure to thermal insulated when passing along the indoor unit.

• When the piping is directed to the right, piping, power Cord and drain pipe should be thermal insulated and fixed onto the back of the unit with a piping fixer.

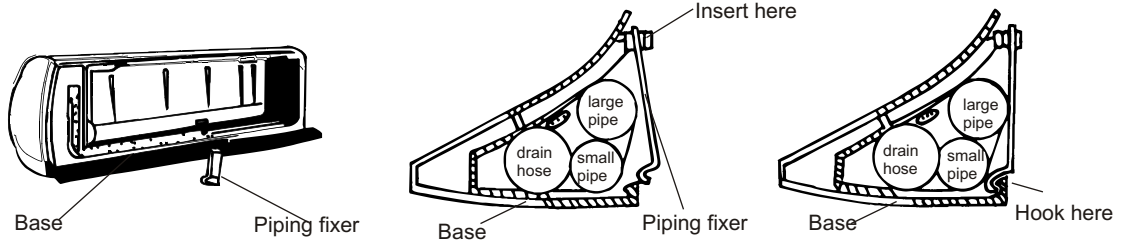

A. Insert the pipe fixer to the slot. B. Press to hook the pipe fixer onto the base.

Piping Connection:

- a. Connect indoor unit pipes with two wrenches. Pay special attention to the allowed torque as shown below to prevent the pipes, connectors and flare nuts from being deformed and damaged.
- b. Pre-tighten them with fingers at first, then use the wrenches.

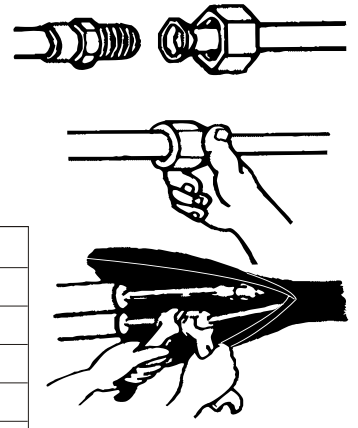

Model	Pipe size	Torque	Nut width
7,9,12,15,16,18K	Liquid Side (Φ 6 or 1/4 inch)	1.8kg.m	17mm
22,24,30K	Liquid Side (Φ 10 or 3/8 inch)	3.5kg.m	22mm
7,9K	Gas Side (Φ 10 or 3/8 inch)	3.5kg.m	22mm
12,15,16,18K	Gas Side (Φ 12 or 1/2 inch)	5.5kg.m	24mm
22,24,30K	Gas Side (Φ 16 or 5/8 inch)	7.5kg.m	27mm

For T3 climate kind models, 18K and 24K Liquid Side is Φ6 (or 1/4 inch).

INSTALLATION INSTRUCTIONS

4. Connecting of the Cable

⚠ If the supply cord is damaged, it must be replaced by the manufacture or its service agent or a similarly qualified person in order to avoid a hazard.

• Indoor Unit

Connect the power connecting cord to the indoor unit by connecting the wires to the terminals on the control board individually in accordance with the outdoor unit connection.

Note: For some models, it is necessary to remove the cabinet to connect to indoor unit terminal.

• Outdoor Unit

- 1). Remove the access door from the unit by loosening the screw. Connect the wires to the terminals on the control board individually as the following.
- 2). Secure the power connecting cord onto the control board with cable clamp.
- 3). Reinstall the access door to the original position with the screw.
- 4) Use a recognized circuit breaker for 24K model between the power source and the unit. A disconnecting device to adequately disconnect all supply lines must be fitted.

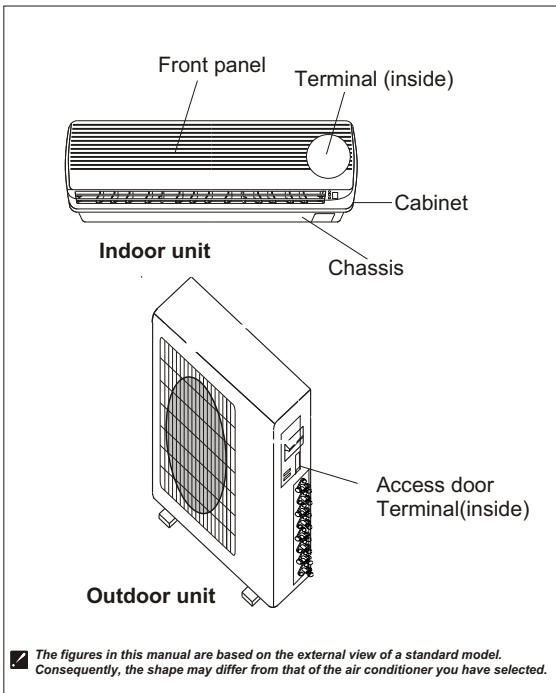

Caution:

1. Never fail to have an individual power circuit specifically for the air conditioner. As for the method of wiring, refer to the circuit diagram posted on the inside of the access door .
2. Confirm that the cable thickness is as specified in the power source specification. (See as the cable specification table below)
3. Check the wires and make sure that they are all tightly fastened after cable connection.
4. Be sure to install an earth leakage circuit breaker in wet or moist area.
5. The appliance must be positioned so that the plug is accessible.

Cable Specifications

For one drive two

Capacity (Btu/h)	Power cord(outdoor)		Signal connecting cord(for heat pump)	
	Type	Normal cross - sectional area	Type	Normal cross - sectional area
7K	H07RN-F	2.5mm ² X3	H07RN-F	0.75mm ² X4
9K	H07RN-F	2.5mm ² X3	H07RN-F	0.75mm ² X4

For one drive three

Capacity (Btu/h)	Power cord(outdoor)		Signal connecting cord	
	Type	Normal cross - sectional area	Type	Normal cross - sectional area
7K	H07RN-F	2.5mm ² X3	H07RN-F	0.75mm ² X2
9K	H07RN-F	2.5mm ² X3	H07RN-F	0.75mm ² X2

Note: Above cables shall be approved by HAR or SAA .

INSTALLATION INSTRUCTIONS

5.Connection diagram of communication signal wire for indoor & outdoor unit is illustrated as follows:

⚠ The appliance shall be installed in accordance to national wiring regulation.Recommend that type of power supply of outdoor unit maybe 245IEC 57 YZW300/500 ,you buy the type power cord with diameter range from 10mm to 12mm.

For one drive two

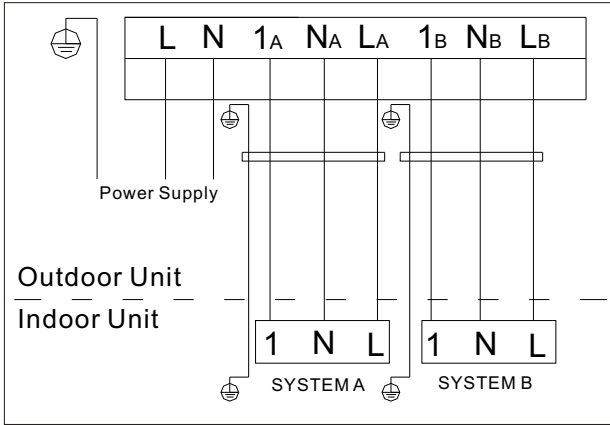

For one drive three

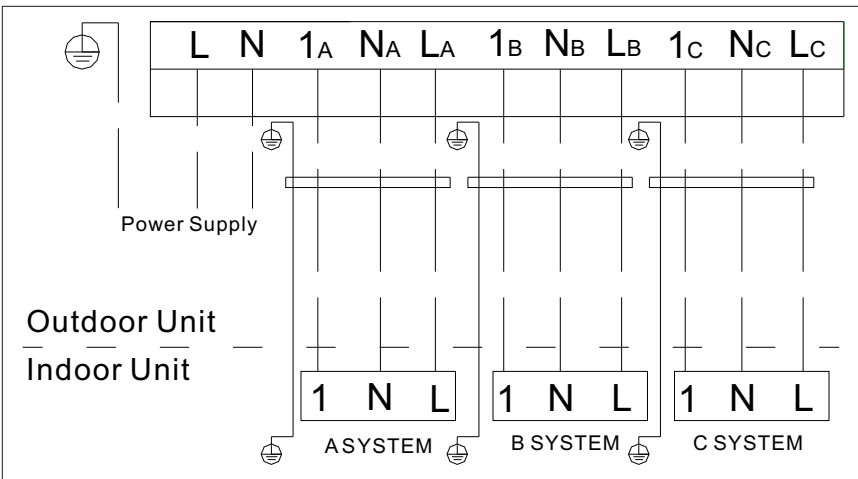

For one drive four

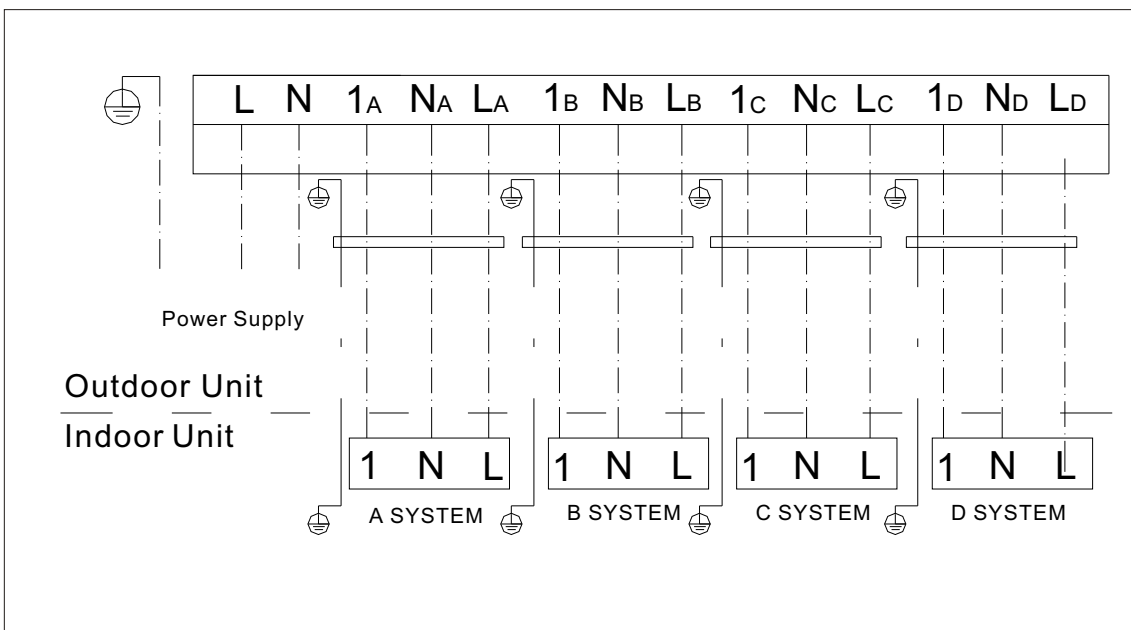

INSTALLATION INSTRUCTIONS

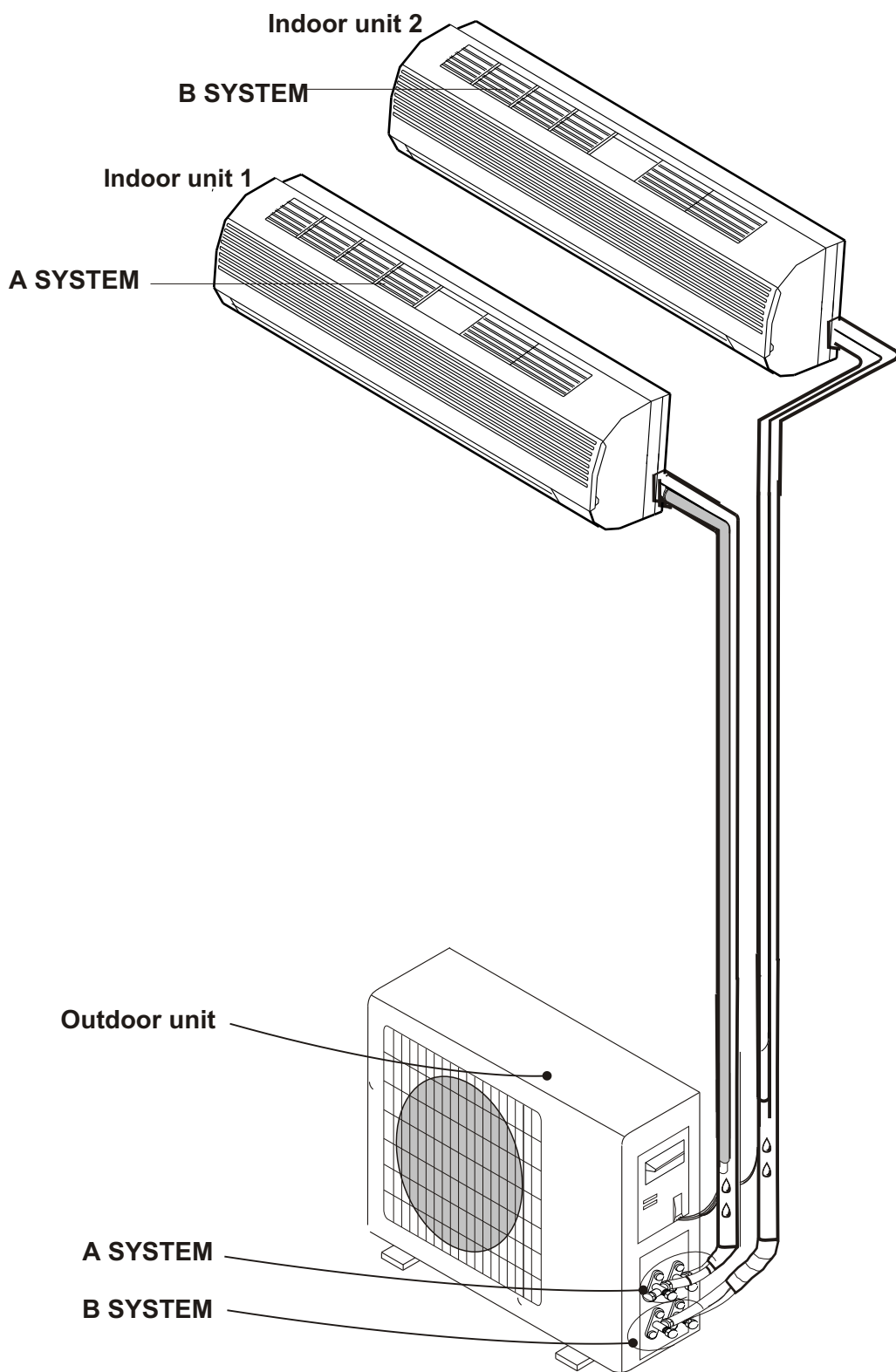

☑ The figures in this manual are based on the external view of a standard model. Consequently, the shape may differ from that of the air conditioner you have selected.

INSTALLATION INSTRUCTIONS

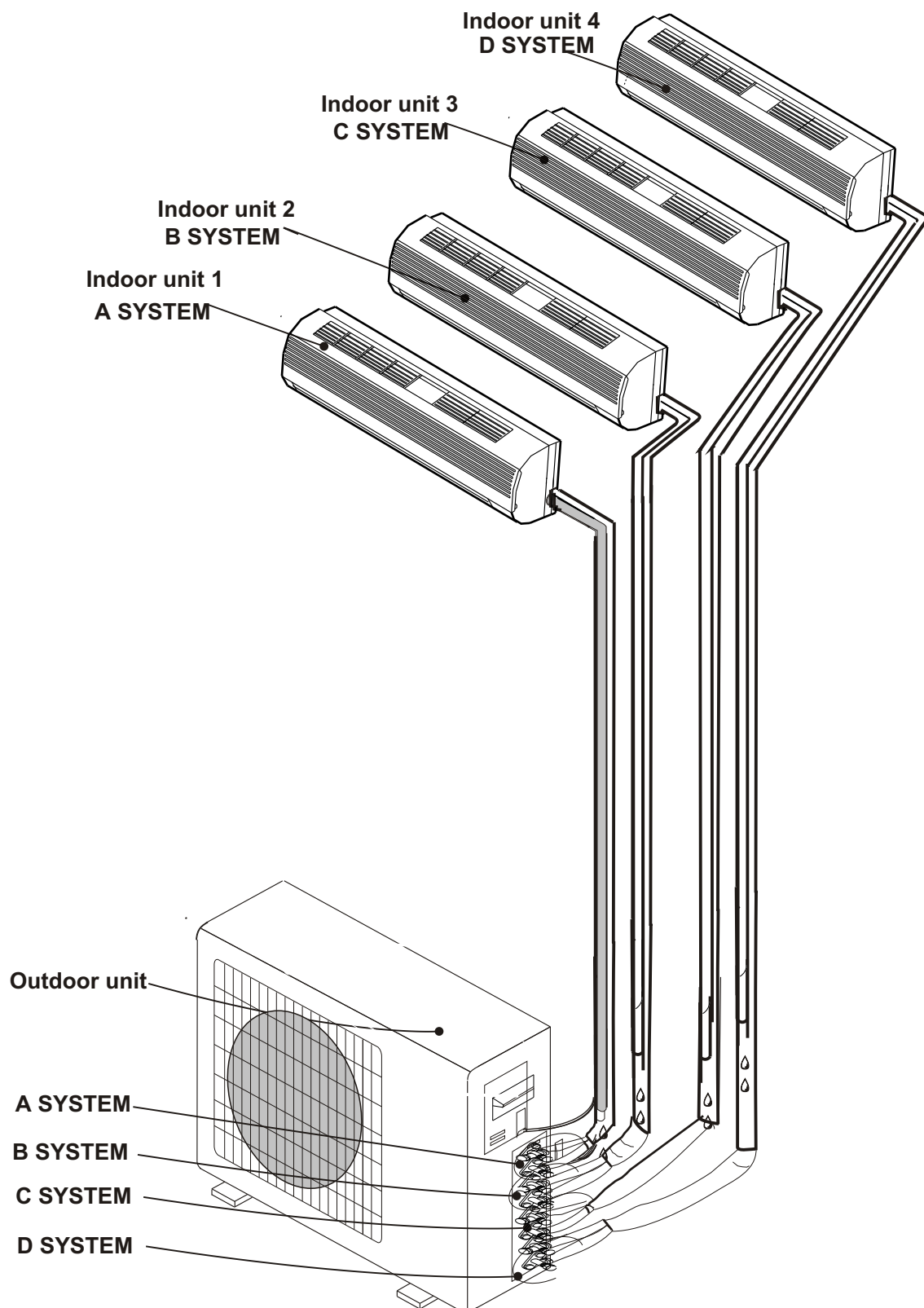

☑ The figures in this manual are based on the external view of a standard model. Consequently, the shape may differ from that of the air conditioner you have selected.

INSTALLATION INSTRUCTIONS

Outdoor unit installation

1. Install Drain Port and Drain Hose (for heat-pump model only)

The condensate drains from the outdoor unit when the unit operates in heating mode. In order not to disturb your neighbor and protect the environment, install a drain port and a drain hose to direct the condensate water. Just install the drain port and rubber washer to the chassis of the outdoor unit, then connect a drain hose to the port as the right figure shown.

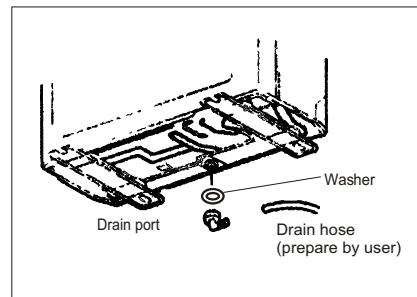

2. Install and Fix Outdoor Unit

Fix with bolts and nuts tightly on a flat and strong floor. If installed on the wall or roof, make sure to fix the supporter well to prevent it from shaking due to serious vibration or strong wind.

3. Distinguish A,B refrigerant system

The two indoor units share a same outdoor unit, but they do not share the same part of condenser, compressor, its connect cable, 4-way valve, linked pipes, stop valves, so defined that refrigerant system using the upper part of condenser as heat exchanger is A system and marked A SYSTEM on the surface of compressor, its connect cable, 4-way valve, stop valves of this refrigerant system, similarly the lower part mark marked B SYSTEM.

4. Outdoor Unit Piping Connection

- Remove the valve caps from the 2-way and 3-way valve.
- Connect the pipes to the 2-way and 3-way valves separately according to the required torque.

5. Outdoor Unit Cable Connection (see previous page)

Air purging

The air which contains moisture remaining in the refrigeration cycle may cause a malfunction on the compressor. After connecting the indoor and outdoor units, evacuate air and moisture from refrigerant cycle using a vacuum pump, as shown below.

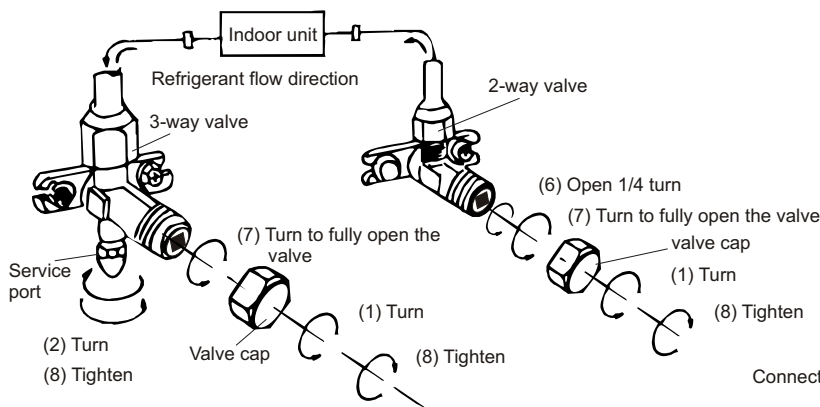
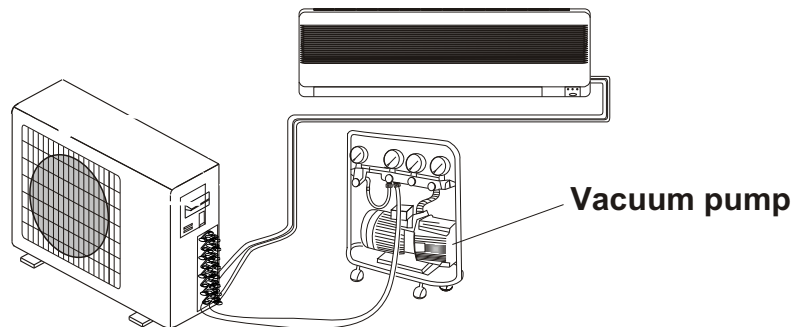

3-way valve diagram

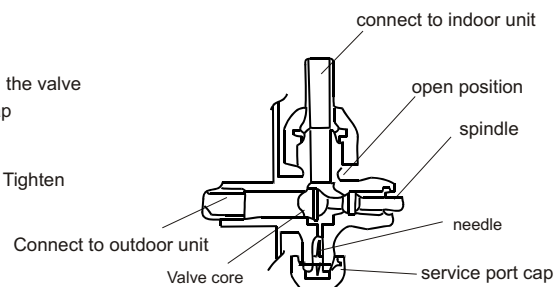

Note: To protect the environment, be sure not to discharge the refrigerant to the air directly.

INSTALLATION INSTRUCTIONS

How to Purge Air Tubes:

- (1). Unscrew and remove caps from 2 and 3-way valves.
- (2). Unscrew and remove cap from service valve.
- (3). Connect vacuum pump flexible hose to the service valve.
- (4). Start vacuum pump for 10-15 minutes until reaching a vacuum of 10 mm Hg absolutes.
- (5). With vacuum pump still running close the low pressure knob on vacuum pump manifold. Then stop vacuum pump.
- (6). Open 2-way valve ? turn then close it after 10 seconds. Check tightness of all joints using liquid soap or an electronic leak detector.
- (7). Turn 2 and 3-way valves stem to fully the valves. Disconnect vacuum pump flexible hose.
- (8). Replace and tighten all valve caps.

Test Running

- Connect to the power source, check if the function selection keys on the remote controller are working properly.
- Check if the room temperature adjustments and timer settings are working properly.
- Check if the drain is smooth.
- Check if there is any abnormal noise or vibration during operation.
- Check if there is leakage of refrigerant.

ATTENTION:

If there is no power plug along with the air conditioner, The power cord should be connected to an air switch ,whose current carrying capacity should be more than 20A and the minimum open-circuit distance among the live polar pole, the neutral polar pole and the ground polar pole should be more than 3mm. If any malfunctions, please cut off the supply by the air switch and contact the manufacturer or its service agent.

The appliance shall be installed in accordance with national wiring regulations.

If the supply cord is damaged. It must be replaced by the manufacturer or its service agent or a similarly qualified person in order to avoid a hazard.



- Please read this manual before installing and using it.
- Do not let air enter the refrigeration system or discharge refrigerant when moving the air conditioner.
- Testing run the air conditioner after finishing installation, and record details of operation.
- Type of fuse used on indoor unit controller for 9K, 12K is 50T, with rating F3.15 A L250V.
Type of fuse used on outdoor unit controller is T20AL250V and F3.15A L250V.
- The fuse for the whole unit is to be provided by the user according to the current at maximum power input or use other over-current protective device instead.
- Accessibility to the plug must be guaranteed even after the installation of the appliance to disconnect it in case of need. If not possible, connect appliance to a double-pole switching device with contact separation of at least 3 mm placed in an accessible position even after installation.

TROUBLE DISPLAY

For easy trial and repair, the troubles and protection are all displayed on indoor unit and outdoor unit.

1. Outdoor unit display the trouble

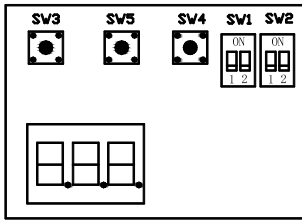

Concert PCB button function

SW3:???button:LED display"Hxx",press???one time,spot check last specification.

SW5:???button:LED display"Hxx",press???one time,spot check next specification.

SW4:in/quit?button?

1. In the spot check mode,press?in/quit?button one time,quit spot check.
2. When power on in first time,press ???button for 5 seconds in 1 minute,LED max value display"H",and compressor start after 5 seconds.
3. SW3+SW5 combination using:when compressor start running for 5 minutes,if press ???and ???at the same time for 5 minutes,and in the period of LED display"HHH", not press anybutton and then in frequency adjustment page,LED display"S**".

Under frequency adjustment page,press???one time,frequency adds 1 Hz.

Under frequency adjustment page,press???one time,frequency reduces 1 Hz.

Under frequency adjustment page,and display "Sxx",press?in/quit?one time,LED displays frequency .

Under frequency adjustment page,and display "Axx",press?in/quit?one time,LED return to normal page.

Note:

1. "xx" is running frequency,and frequency adjustment range is Fm_L--Fm_H.
2. Except frequency adjustment page,if there is no button press operation,the LED returns to normal page automatically.

TROUBLE DISPLAY

More trouble codes and reasons showed as below:

LED code	Protection/Trouble type	Indication light code
E0	I/U & O/U communicate trouble	RUN, TIMER -both flash
EC	O/U communicate trouble	RUN, TIMER -both flash
E1	I/U sensor trouble	RUN-1 time/8second
E2	Inner pipe temp. sensor trouble	RUN-2 time/8second
E3	Outer pipe temp. sensor trouble	RUN-3 time/8second
E4	System unnormal	RUN-4 time/8second
E5	Model allocation trouble	RUN-5 time/8second
E6	I/U vane motor trouble	RUN-6 time/8second
E7	O/U temp. sensor trouble	RUN-7 time/8second
E8	Discharge temp. sensor trouble	RUN-8 time/8second
E9	Invert board trouble	RUN-9 time/8second
EF	O/U vane motor trouble	RUN-10 time/8second
EA	Current sensor trouble	RUN-11 time/8second
EE	EEPROM trouble	RUN-12 time/8second
EP	High/Low pressure protection	RUN-13 time/8second
EU	Voltage sensor trouble	RUN-14 time/8second
EH	Gas return sensor trouble	RUN-15 time/8second
	Clash mode	
P1	Over, lower voltage protection	RUN-flash, TIMER-1 time/8second
P2	Over current protection	RUN-flash, TIMER-2 time/8second
P4	High temp of discharge gas protection	RUN-flash, TIMER-4 time/8second
P5	Over cooling protection	RUN-flash, TIMER-5 time/8second
P6	Prevent over heating in cooling mode protection	RUN-flash, TIMER-6 time/8second
P7	Prevent over heating in heating mode protection	RUN-flash, TIMER-7 time/8second
P8	Over hot or lower cooling of O/U protection	RUN-flash, TIMER-8 time/8second
P9	Drive protection (load unnormal)	RUN-flash, TIMER-9 time/8second
P0	Board protection	RUN-flash, TIMER-10 time/8second

Note: flashshine 0.5second, out 0.5second
n time/8secondshine 0.3second, out 0.3second

TROUBLE DISPLAY

Attachment 1: Concert PCB trouble code

Display	Protection/trouble type	Reason
EEA	EEPROM trouble	Concert PCB EEPROM trouble
EEB	EEPROM trouble	PCB EEPROM trouble
E0	O/U inverter board communicate trouble	Concert PCB and drive board without communication or unnormal
EC	Concert PCB and drive board communicate trouble	Power source board and inverter board communicate unnormal
E0A	1#I/U communication trouble	1# I/U & O/U without communication or normal
E0b	2#I/U communication trouble	2# I/U & O/U without communication or normal
E0c	3#I/U communication trouble	3# I/U & O/U without communication or normal
E0d	4#I/U communication trouble	4# I/U & O/U without communication or normal
E9	Drive or inverter board trouble	3 times drive or board protection in 30 minutes
EP	High/Low pressure protection	Unit pressure too high/low
EU	Voltage sensor trouble	System can not sampling voltage
E3	T3temp.sensor trouble	O/U pipr temp.sensor short out or open circuit
E7	T4temp.sensor trouble	O/U condition temp.temp.sensor short out or open circuit
E8	Discharge gas temp.sensor trouble	Discharger gas temp.sensor short out or open circuit
EH	Gas return temp.sensor trouble	Gas return temp.sensor short out or open circuit
EtA	1# T2B1temp.sensor trouble	1# O/U outer pipe temp.sensor short out or open circuit
Etb	2# T2B2temp.sensor trouble	2# O/U outer pipe temp.sensor short out or open circuit
Etc	3# T2B3temp.sensor trouble	3# O/U outer pipe temp.sensor short out or open circuit
Etd	4# T2B4temp.sensor trouble	4# O/U outer pipe temp.sensor short out or Open circuit
P0	IPM protection	Compressor drive unnormal
P9	Compressor drive unnormal protection	Compressor drive unnormal or not start
P9	Capacity Dip switch unnormal protection	Drive board is not match with compressor type
P1	Lower voltage protection	Input voltage lower than 160V ±5V
P2	Compressor current protection	Running current higher than limited value
P4	Higher temp.of discharge gas	Discharger temp. Higher than protection value in shut down condition
H1	High voltage switch protection	High pressure switch unnormal
H2	Low voltage switch protection	Low pressure switch unnormal
H6	Prevent over heating protection in T3	In cooling mode,O/U pipe temp. Higher than setting value

TROUBLE DISPLAY

Attachment 2: Indoor unit protection and trouble code list

Display Code	Protection/trouble type	Reason
P1	Lower voltage protection	Lower voltage protection
P2	Over current protection	Input voltage lower than 160V±5V
P4	High temp of discharge gas protection	Discharge temp. higher than shutdown Protection value
P5	Prevent over cooling in cooling mode protection	In cooling mode, I/U pipe temp. lower than Setting value
P6	Prevent over heating in cooling mode protection	In cooling mode, O/U pipe temp. lower than Setting value
P7	Prevent over heating in heating mode protection	In heating mode, I/U pipe temp. higher than setting value
P8	Over hot or lower cooling of O/U protection	In cooling mode, O/U lower than 0°C Or In heating mode, O/U higher than 32°C
P9	Drive protection	Compressor drives abnormal or not start
P0	Board protection	Inverter module overheating or over current Protection
E0	I/U & O/U communicate trouble	No communication with I/U and O/U, Or outdoor power source board abnormal
EC	O/U communicate trouble	Communication abnormal between outdoor power source board and inverter board
E1	I/U environment temp. sensor trouble	Short or open circuit of I/U temp. Sensor
E2	Inner pipe temp. sensor trouble	Short or open circuit of I/U pipe temp. Sensor
E3	Outer pipe temp. sensor trouble	Short or open circuit of O/U temp. Pipe sensor
E4	I/U vane motor trouble	Abnormal change of inner pipe in cooling and heating mode
E6	O/U temp. sensor trouble	I/U fan can't run or run abnormally
E7	O/U temp. sensor trouble	Short or open circuit of O/U temp. Sensor
E8	Discharge temp. sensor trouble	Short or open circuit of O/U discharge temp. Sensor
E9	Invert board trouble	Drive or module protection action in 30 minutes for more times
EF	O/U vane motor trouble	O/U fan motor can't run or run abnormally
EA	Current sensor trouble	System can't collect current sample
EE	I/U EEPROM trouble	Can't read EEPROM data
EE	O/U EEPROM trouble(both I/U and O/U show EE)	Can't read EEPROM data
EP	High/Low pressure protection	Unit pressure too high/low
EU	Voltage sensor trouble	System can't collect voltage sample
EH	Gas return temp. sensor trouble	Short or open circuit of gas return sensor